

PART NUMBER 30028218 (LEGACY PART: 90022273)	HEAT TREAT	MATERIAL		WEIGHT APPROX	YPF ARGENTINA CATALOG DRAWING, TUBING HANGER CFB 11" NOMINAL, 4-1/2" BLANK PIN BOTTOM FOR 13.5 lb/ft TENARIS BLUE THREAD X 5.500-4 STUB ACME-2G RH BOX TOP, 4 H BPV THREAD	DWG. No. RB-42863
		SPEC	DWG No	237 lbs		REV: 0 SHEET 1 OF 2
				SCALE 0.250		

BILL OF MATERIALS			
ITEM	PART NUMBER	DESCRIPTION	QTY
10	30028218	STREAM-FLO CROWN CASING HANGER MANDREL (UPPER STRING) CFB 11 NOMINAL X 4-1/2 BLANK PIN BOTTOM FOR 13.5 lb/ft TENARIS BLUE THREAD X 5.500-4 STUB ACME-2G RH BOX TOP 7.07 DIAMETER X 6.00 EFFECTIVE LENGTH EXTENDED NECK AND 9.125 DIAMETER FOR PACKOFF BUSHING WITH 4 H BPV THREADS AND SIX FLUTES 3.88 BORE 32.56 OAL 125K MATERIAL API 6A UAA PSL-2 PRI MAX LOAD 525000 LBS	1

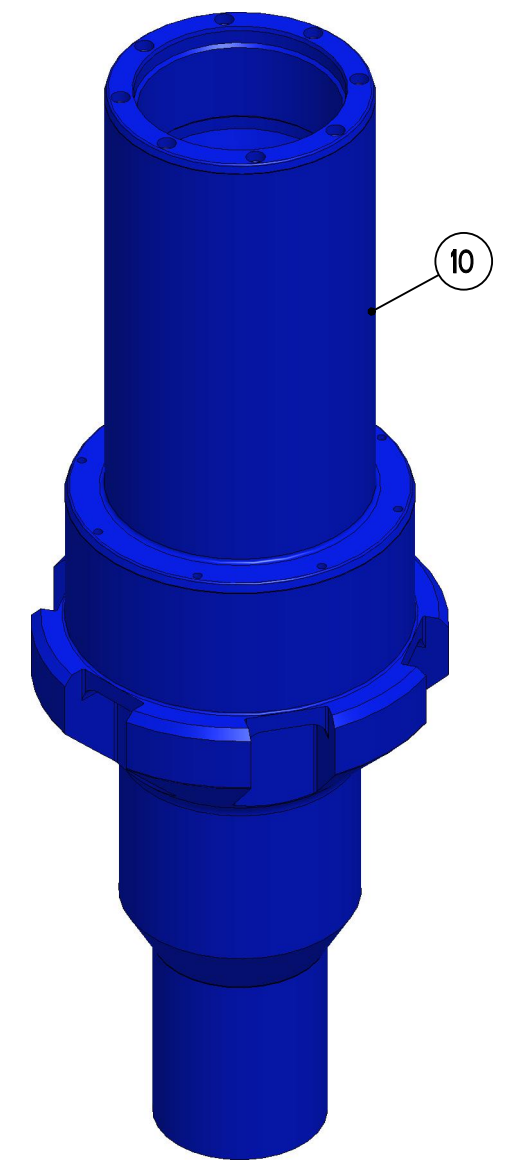
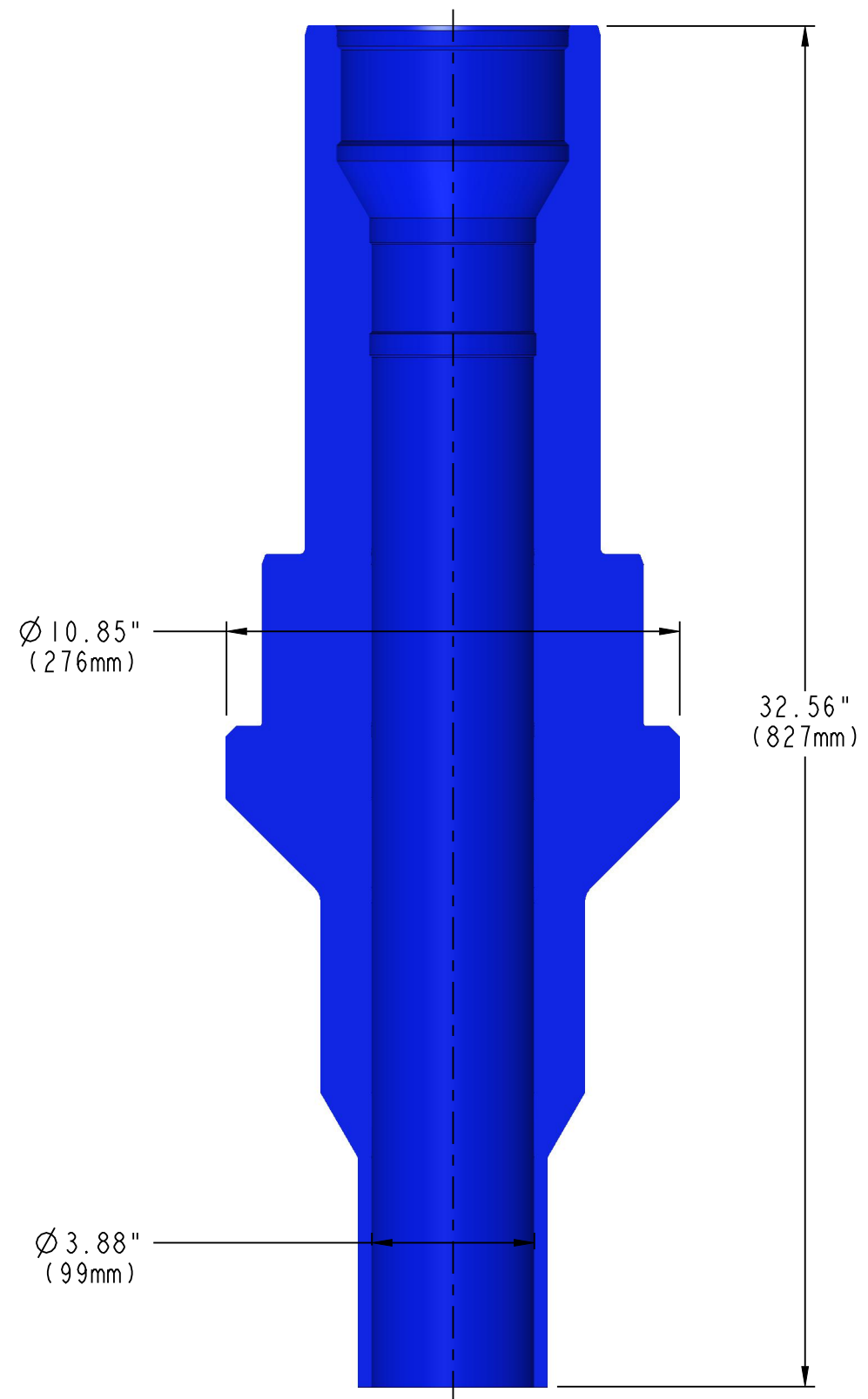

3D VIEW
SCALE 0.200

REV.	EC	BY	DATE	DWN.	GAK	12-20-22	ALL DIMENSIONS IN INCHES UNLESS OTHERWISE NOTED: .X +/- .1 .XX +/- .02 .XXX +/- .005	ANGLE +/- 1/2° RAD .05 T.I.R. .010	THIS DOCUMENT IS A PROPERTY OF STREAM-FLO INDUSTRIES LTD. AND NOT TO BE USED IN ANY WAY PREJUDICIAL TO THEIR INTERESTS. ALL PROPRIETARY RIGHTS RESERVED.		4505 - 74 AVE. EDMONTON, ALTA. CANADA
				CHCK.	JG	12-21-22					
				APPR.	RM	12-21-22					
				BY		DATE					

PART NUMBER 30028218 (LEGACY PART: 90022273)	HEAT TREAT	MATERIAL		WEIGHT APPROX	YPF ARGENTINA CATALOG DRAWING, TUBING HANGER CFB 11" NOMINAL, 4-1/2" BLANK PIN BOTTOM FOR 13.5 lb/ft TENARIS BLUE THREAD X 5.500-4 STUB ACME-2G RH BOX TOP, 4 H BPV THREAD	DWG. No. RB-42863
		SPEC	DWG No	237 lbs		REV: 0 SHEET 2 OF 2
				SCALE 0.250		

LISTA DE MATERIALES			
ARTICULO	NUMERO DE PARTE	DESCRIPCION	CANT.
10	30028218	COLGADOR DE CASING TIPO MANDREL II NOMINAL X 4-1/2 APTO PARA ROSCA INFERIOR PARA 13,5 lb/ft TENARIS BLUE Y 5.500-4 STUB ACME BOX SUPERIOR CON CUELLO EXTENDIDO PARA SELLAR EN PACKOFF CON PREPARACION PARA VALVULA BPV H DE 4 Y 6 PASAJES PARA LODO 3.88 BORE MATERIAL 125K API 6A U/AA/PSL-2/PRI 525000 LBS DE CARGA MAMIMA	1

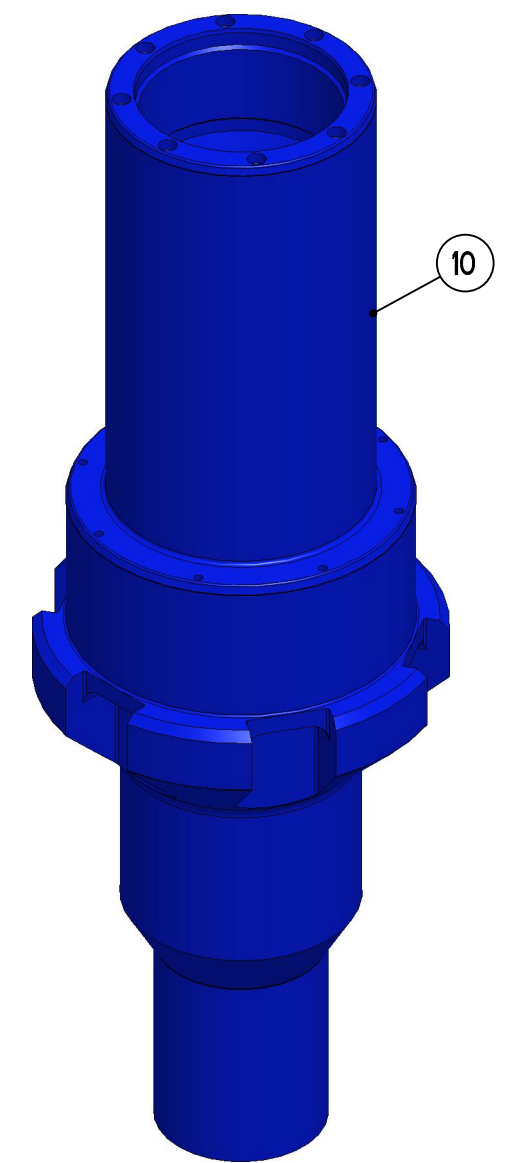
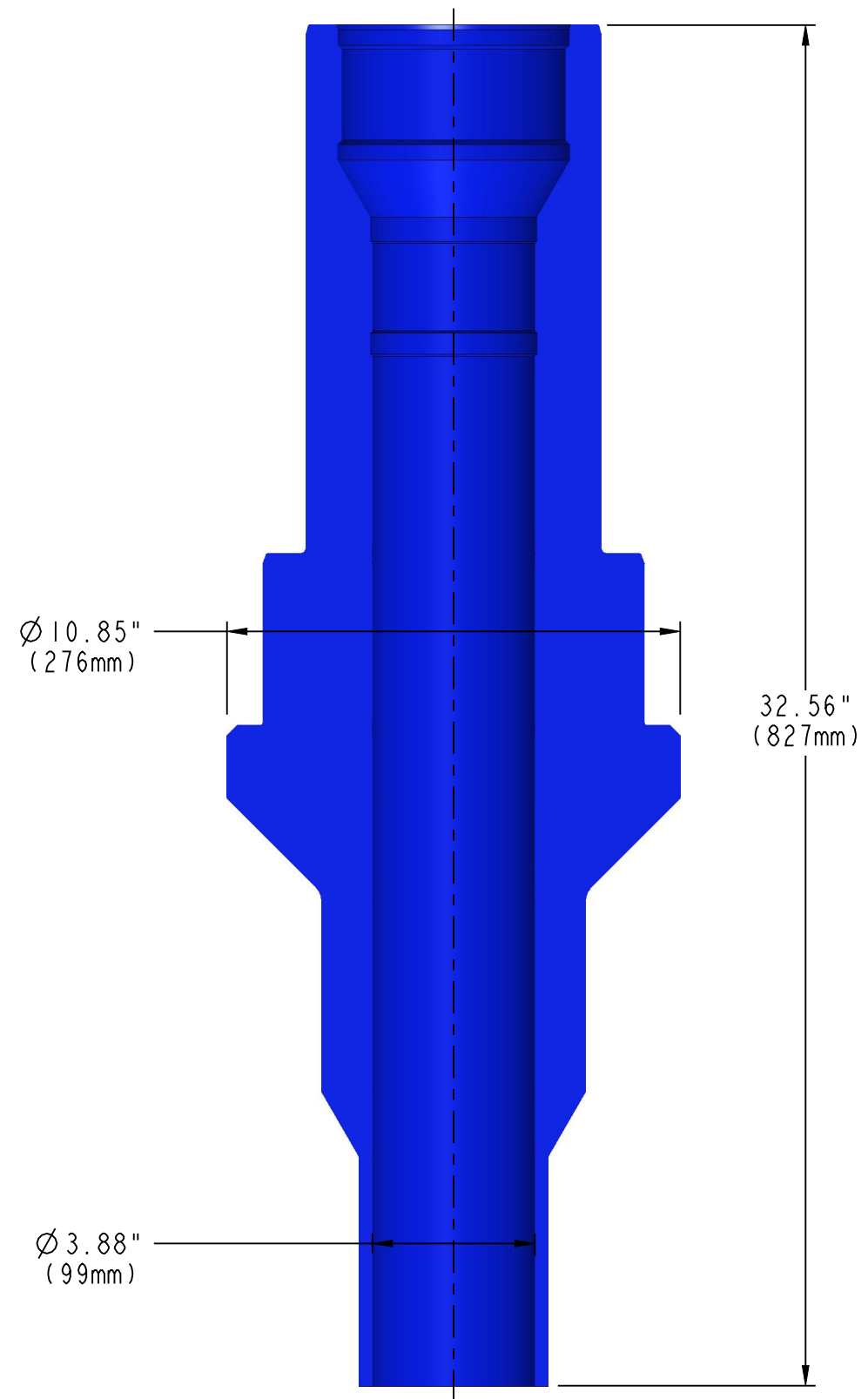

3D VIEW
SCALE 0.200

REV.	EC	BY	DATE	DWN.	GAK	12-20-22	ALL DIMENSIONS IN INCHES UNLESS OTHERWISE NOTED: .X +/- .1 .XX +/- .02 .XXX +/- .005 ANGLE +/- 1/2° RAD II .05 T.I.R. .010		THIS DOCUMENT IS A PROPERTY OF STREAM-FLO INDUSTRIES LTD. AND NOT TO BE USED IN ANY WAY PREJUDICIAL TO THEIR INTERESTS. ALL PROPRIETARY RIGHTS RESERVED.		4505 - 74 AVE. EDMONTON, ALTA. CANADA
				CHCK.	JG	12-21-22					
				APPR.	RM	12-21-22					
							MODEL: 42863_30028218				