

PART NUMBER 30203766 (LEGACY PART: 90021984)	HEAT TREAT	MATERIAL		WEIGHT APPROX	CASING HANGER ASSEMBLY CFB 11" X 9-5/8" TENARIS XP BUTTRESS (36.0 LB/FT) BOX BOTTOM WITH SPLIT LANDING BASE AND 10.500-2 STUB ACME-3G THREADED FLANGE	DWG. No. RB-42604
		SPEC	DWG No	675 lbs		REV: 0 SHEET 1 OF 2
				SCALE 0.250		

LIST OF MATERIALS			
ITEM	PART NUMBER	DESCRIPTION	QTY
10	30010391	CASING HANGER MANDREL CFB 11 NOMINAL WITH 9-5/8 TENARIS XP BUTTRESS (36.0 lb/ft) BOX BOTTOM X 10.500-2 STUB ACME-3G RH PIN LIFT THREAD TOP 9.70 DIAMETER X 6.00 EFFECTIVE LENGTH SLICK EXTENDED NECK WITH 12.38 LANDING BASE PREP 8.81 BORE 21.00 LONG 80 ksi MINIMUM YIELD 4130 MATERIAL API 6A PUDD PSL-2 PRI *MAX LOAD 400000 lbf	1
20	30028484	LANDING BASE ASSEMBLY SPLIT 27.00 OD X 14.00 ID X 9.25 TALL WITH 1.50 THICK BOTTOM PLATE AND SIX RIBS TO LAND ON CELLAR FLOOR MAX LOAD 400000 lbs	1
30	30010390	THREADED ROTATING FLANGE RING CFB FOR LANDING MANDREL WITH 10.500-2 STUB ACME-3G THREAD 10.20 BORE 4.88 LONG API 6A PUDD PSL-2 PRI	1

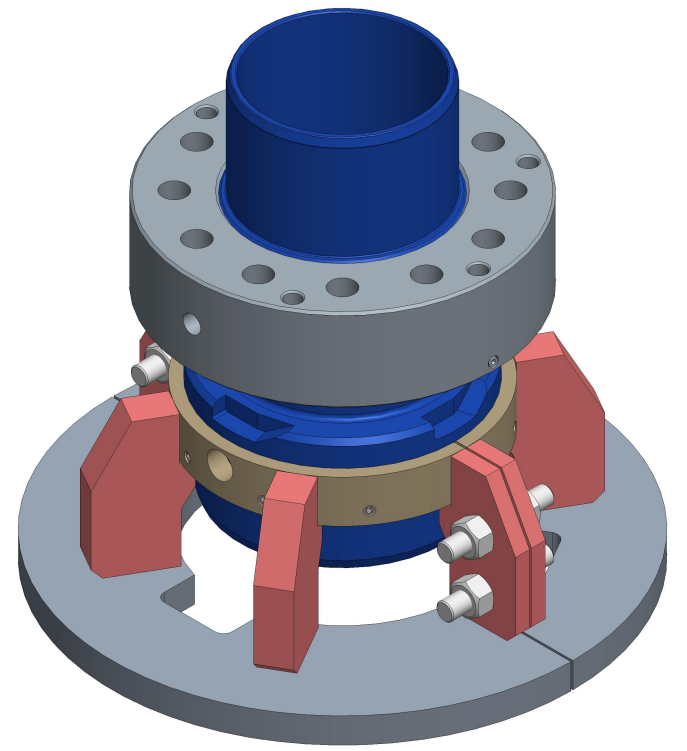
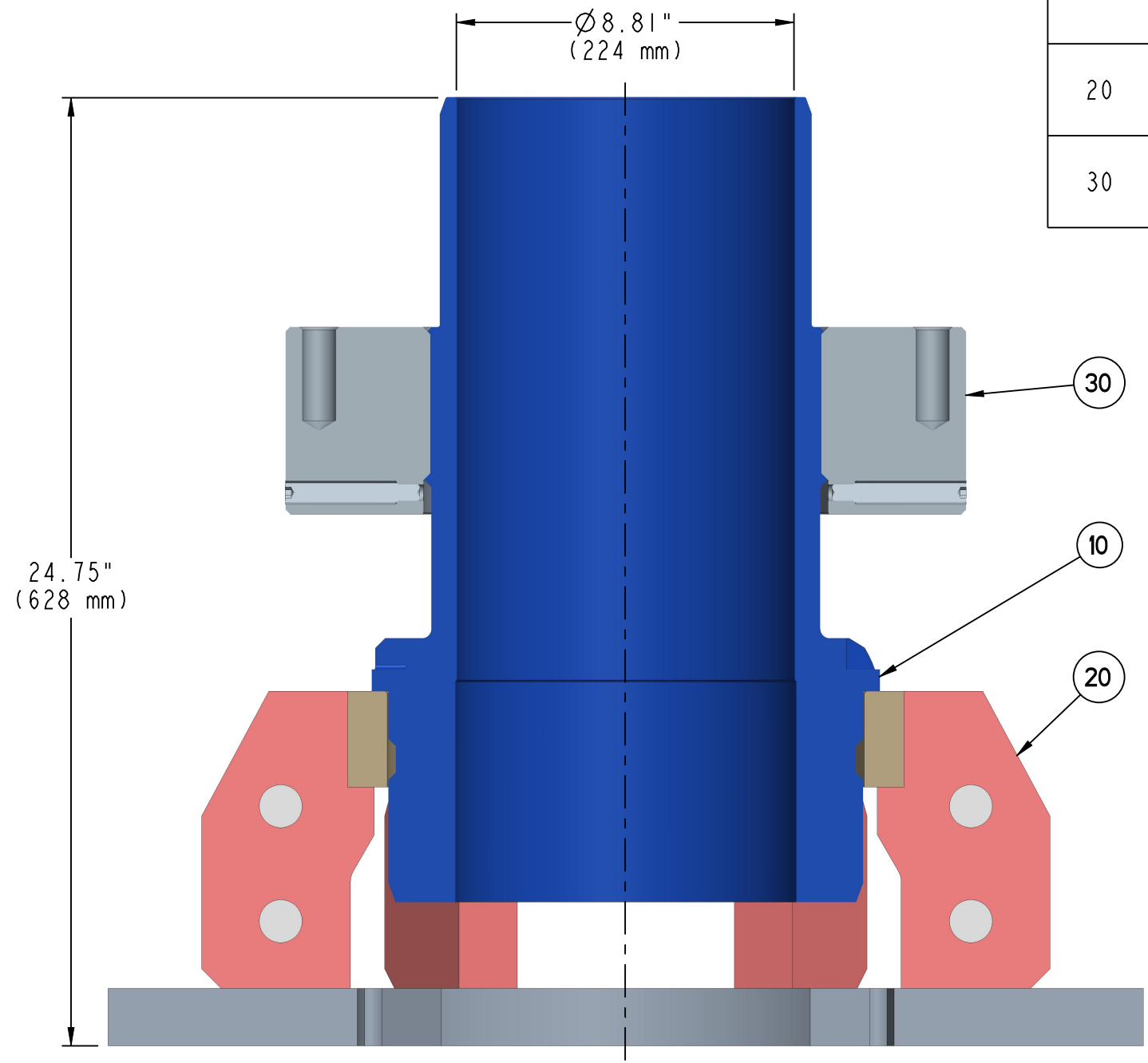

3D VIEW
SCALE 0.125

REV.	EC	BY	DATE	DWN.	GAK	11-08-22	ALL DIMENSIONS IN INCHES UNLESS OTHERWISE NOTED: .X +/- .1 .XX +/- .02 .XXX +/- .005	ANGLE +/- 1/2° RAD II .05 T.I.R. .010	THIS DOCUMENT IS A PROPERTY OF STREAM-FLO INDUSTRIES LTD. AND NOT TO BE USED IN ANY WAY PREJUDICIAL TO THEIR INTERESTS. ALL PROPRIETARY RIGHTS RESERVED.	4505 - 74 AVE. EDMONTON, ALTA. CANADA
				CHCK.	AT	11-29-22				
				APPR.	RM	11-29-22				
				BY		DATE				

