

PART NUMBER	HEAT TREAT	MATERIAL		WEIGHT APPROX	YPF ARGENTINA CATALOGUE DRAWING 11" NOMINAL CFB SOLID MANDREL 7-5/8" (24 lb/ft) WEDGE 463MS THREAD 125KSI UAA PSL-2 PR1	DWG. No. RB-42737
		SPEC	DWG No			
30202686				SCALE 0.375		REV: 0 SHEET 1 OF 2

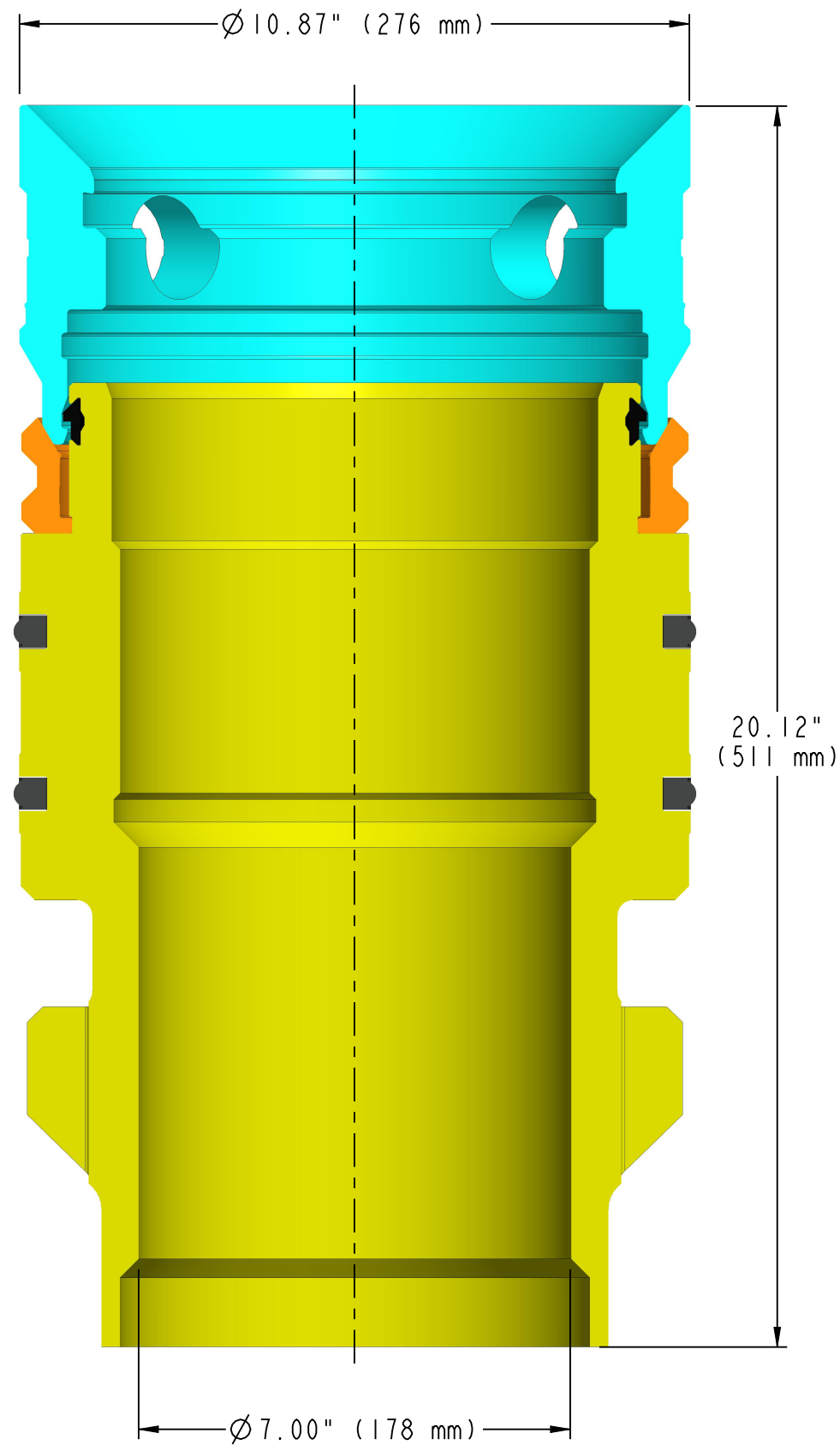

BILL OF MATERIALS			
ITEM	PART NUMBER	DESCRIPTION	QTY
10	30202686	STREAM-FLO CROWN CASING HANGER SOLID MANDREL (LOWER STRING) CFB 11 NOMINAL X 7-5/8 TENARISHYDRIL WEDGE 461MS (24.00 lb/ft) BOX BOTTOM X 7.750-4 STUB ACME-2G RH BOX TOP DUAL BODY S-SEALS LOCKDOWN RING ELASTOMER RETENTION RING SIX FLUTES ON LOAD SHOULDER FOR OUTLET COMMUNICATION 7.00 BORE 125 ksi MINIMUM YIELD MATERIAL API 6A UAA PSL-2 PR1 *MAX LOAD 575000 lbs	1

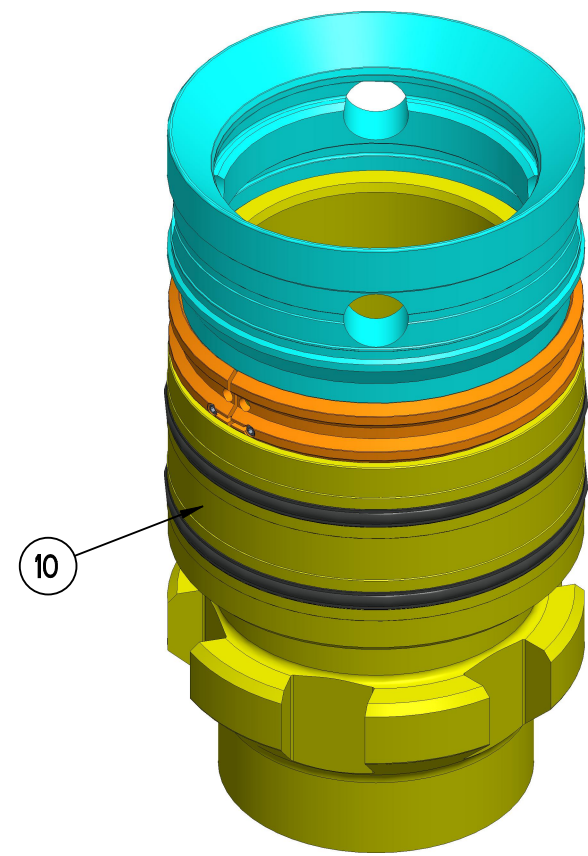

3D VIEW
SCALE 0.200

REV.	EC	BY	DATE	DWN.	VN	11-30-22	ALL DIMENSIONS IN INCHES UNLESS OTHERWISE NOTED: .X +/- .1 .XX +/- .02 .XXX +/- .005	ANGLE +/- 1/2° RADIUS .05 T.I.R. .010	THIS DOCUMENT IS A PROPERTY OF STREAM-FLO INDUSTRIES LTD. AND NOT TO BE USED IN ANY WAY PREJUDICIAL TO THEIR INTERESTS. ALL PROPRIETARY RIGHTS RESERVED.	4505 - 74 AVE. EDMONTON, ALTA. CANADA
				CHCK.	GAK	11-30-22				
				APPR.	RM	11-30-22				

PART NUMBER	HEAT TREAT	MATERIAL		WEIGHT APPROX	YPF ARGENTINA CATALOGUE DRAWING 11" NOMINAL CFB SOLID MANDREL 7-5/8" (24 lb/ft) WEDGE 463MS THREAD 125KSI UAA PSL-2 PR1	DWG. No. RB-42737
		SPEC	DWG No			
30202686				SCALE 0.375		REV: 0 SHEET 2 OF 2

LISTA DE MATERIALES			
ARTICULO	NUMERO DE PARTE	DESCRIPCION	CANT.
10	30202686	COLGADOR DE CASING TIPO MANDREL INTEGRAL 11" NOMINAL X 7-5/8" TENARIS HYDRIL WEDGE 461MS (24.00 lb/ft) BOX INFERIOR Y ROSCA 7.750-4 STUB ACME-2G RH BOX SUPERIOR CON DOBLE SELLO, PREPARADO PARA ANILLO DE RETENCION INTERNO CON 6 PASAJES, 7.00" BORE, 10.000 psi, *MAX CARGA ADMISIBLE: 575000 lbs* MATERIAL 125K. API 6A U/AA/PSL2/PR1	1

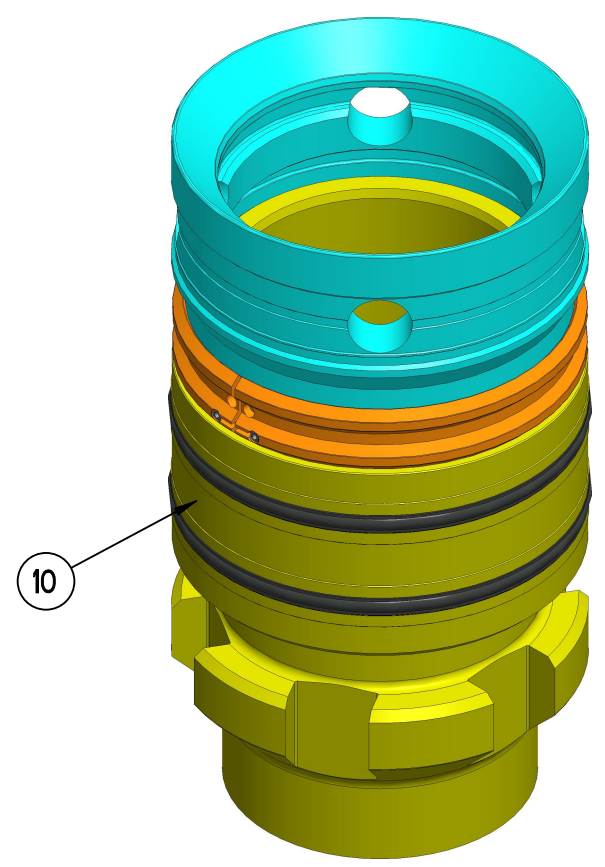
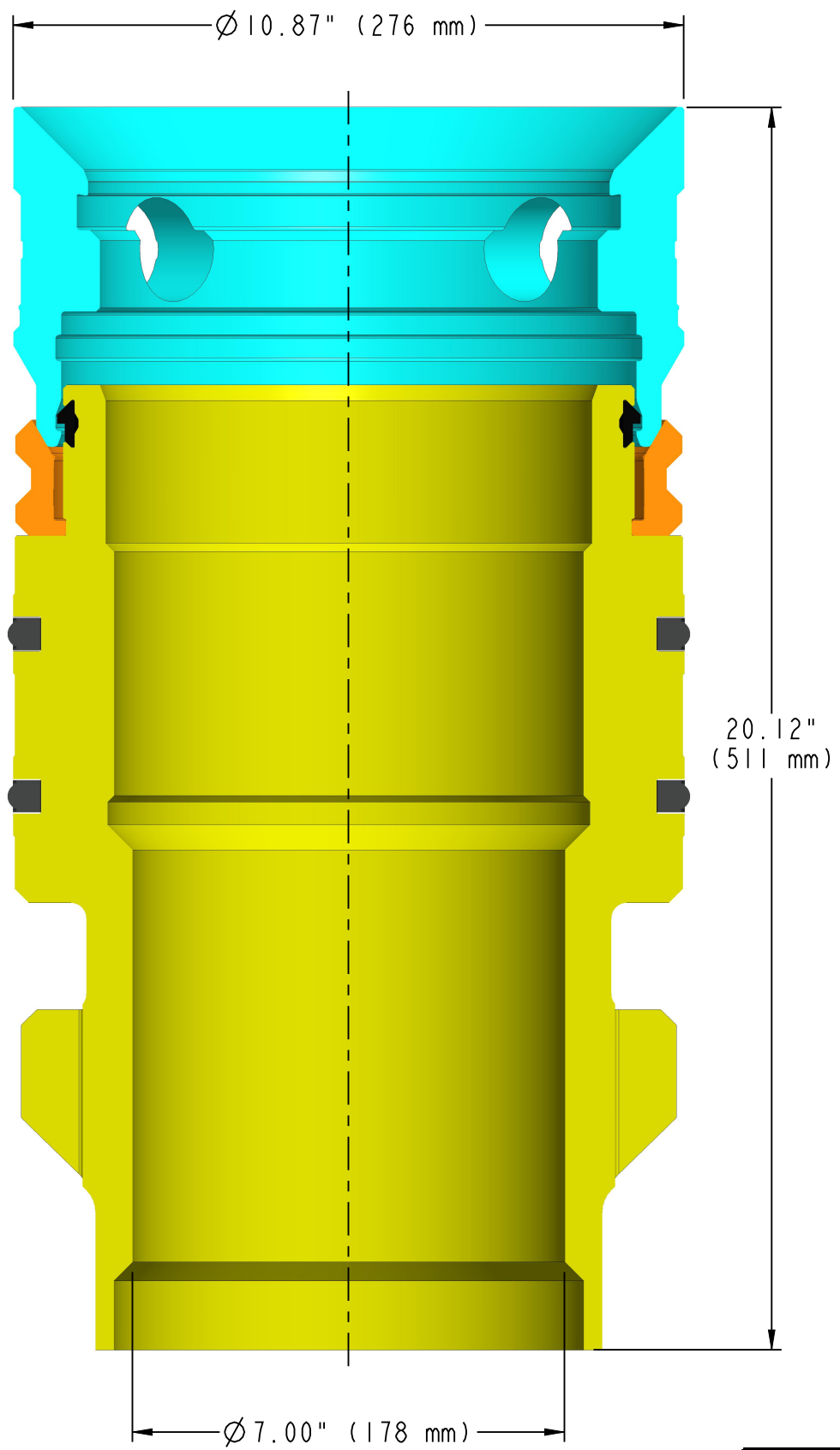

3D VIEW
SCALE 0.200

DWN.	VN	11-30-22	ALL DIMENSIONS IN INCHES			THIS DOCUMENT IS A PROPERTY OF STREAM-FLO INDUSTRIES LTD. AND NOT TO BE USED IN ANY WAY PREJUDICIAL TO THEIR INTERESTS. ALL PROPRIETARY RIGHTS RESERVED.		
CHCK.	GAK	11-30-22	UNLESS OTHERWISE NOTED:					
APPR.	RM	11-30-22	.X	+/-	.1	ANGLE	+/-	1/2°
REV.	EC	BY	DATE	BY	DATE	.XX	+/-	.02
						.XXX	+/-	.005
								250
								125
								RAD 11
								T.I.R.
								.010

