

PART NUMBER 30203876 (LEGACY PART: 90022591)	HEAT TREAT	MATERIAL		WEIGHT APPROX	ADAPTER FLANGE ASSEMBLY DR-1 11 10000 RSF THREADED FLANGE OEC X 5-1/8 15000 STUDDED TOP 7 TYPE DR-1 METAL SEAL AND ONE 7 FS-SEAL PREP FOR 6 EFFECTIVE LENGTH EXTENDED NECK HANGER COMES WITH BX-158 RING GASKET AND PREP FOR TYPE FM DUAL BARRIER SEAL	DWG. No. RB-42731
		SPEC	DWG No	1124 lbs		
				SCALE 0.200		REV: 0 SHEET 1 OF 2

LIST OF COMPONENTS			
ITEM	PART NUMBER	DESCRIPTION	QTY
10	30028908	STREAM-FLO CROWN ADAPTER FLANGE DR-1 16.250-2 STUB ACME-2G PIN THREAD BOTTOM FOR RSF THREADED FLANGE AND BX-158 GROOVE OEC X 5-1/8 15000 STUDDED TOP 7 TYPE DRI METAL SEAL AND ONE 7 FS-SEAL PREP FOR 6 EFFECTIVE LENGTH EXTENDED NECK HANGER TYPE FM DUAL BARRIER SEAL 5.12 BORE 8.50 LONG API 6A PUEE PSL-3 PR2F	1
20	10011695	RING GASKET BX-158 LOW CARBON STEEL PLATED S-4 API 6A	1
30	30028943	STREAM-FLO CROWN THREADED FLANGE RING RSF 11 10000 STUDDED BOLT PATTERN X 16.250-2 STUB ACME-2G RH INTERNAL THREADS 5.56 LONG NON-EXPOSED (B7/2H) BOLTING API 6A PUEE PSL-2	1

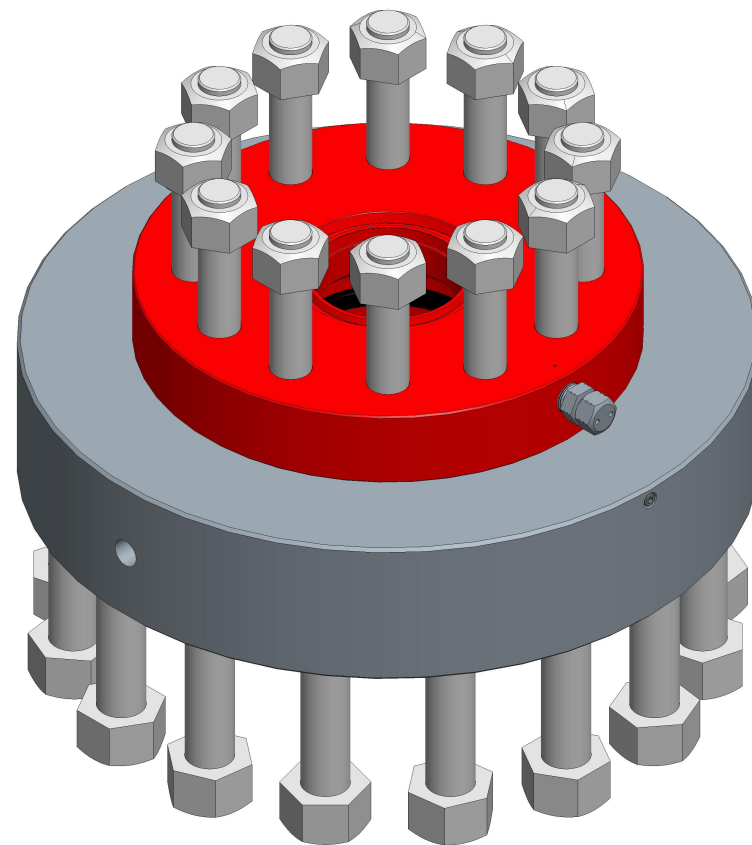
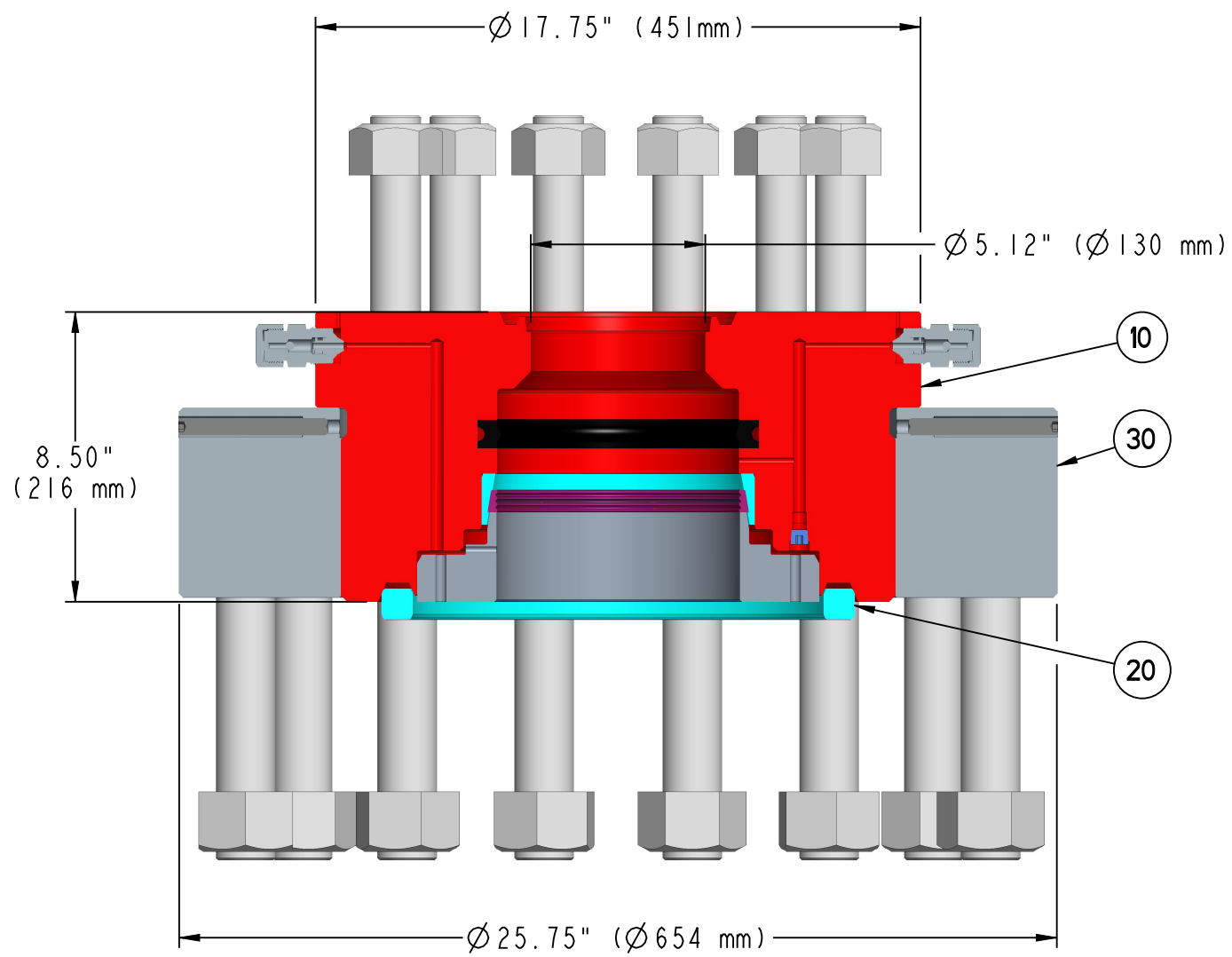

3D VIEW  
SCALE .200

REV.	EC	BY	DATE	DWN.	AT	11-25-22	ALL DIMENSIONS IN INCHES UNLESS OTHERWISE NOTED: .X +/- .1 .XX +/- .02 .XXX +/- .005	ANGLE +/- 1/2° RADII .05 T.I.R. .010	THIS DOCUMENT IS A PROPERTY OF STREAM-FLO INDUSTRIES LTD. AND NOT TO BE USED IN ANY WAY PREJUDICIAL TO THEIR INTERESTS. ALL PROPRIETARY RIGHTS RESERVED.	4505 - 74 AVE. EDMONTON, ALTA. CANADA									
				CHCK.	GAK	11-29-22													
				APPR.	JG	11-29-22													
				BY															
REF: WH-22591				COMMONSPACE				PROJ: 7813				MODEL: 42731_30203876				DWG: 42731_30203876			

PART NUMBER 30203876 (LEGACY PART: 90022591)	HEAT TREAT	MATERIAL		WEIGHT APPROX	ADAPTER FLANGE ASSEMBLY DR-1 11 10000 RSF THREADED FLANGE OEC X 5-1/8 15000 STUDDED TOP 7 TYPE DR-1 METAL SEAL AND ONE 7 FS-SEAL PREP FOR 6 EFFECTIVE LENGTH EXTENDED NECK HANGER COMES WITH BX-158 RING GASKET AND PREP FOR TYPE FM DUAL BARRIER SEAL	DWG. No. RB-42731
		SPEC	DWG No	1124 lbs		
				SCALE 0.200		REV: 0 SHEET 2 OF 2

LISTA DE MATERIALES			
ARTICULO	NUMERO DE PARTE	DESCRIPCION	CANT.
10	30028908	BRIDA ADAPTADORA STREAM-FLO CROWN MODELO DR-1 CON ROSCA EXTERNA INFERIOR 16.250-2 STUB ACME-2G PIN Y RANURA PARA ANILLO EMPAQUETADOR ESTANDAR BX-158 Y SUPERIOR ESPARRAGADO 5-1/8 15000 CON PREPARACION PARA SELLO METAL-METAL TIPO DR-1 Y SELLO DE RESPALDO ELASTOMERICO TIPO FS, LA PREPARACION SUPERIOR INCLUYE PREPARACION PARA SELL METAL-METAL REDUNDANTE TIPO FM ADICIONAL (DOBLE BARRERA CON ANILLO API), 5.12 BORE 8.50, API 60 PUEE PSL-3 PR2F	1
20	10011695	ANILLO EMPAQUETADOR BX-158 ACERO BAJO CARBONO CON RECUBRIMIENTO S-4 API 6A	1
30	30028943	BRIDA ROSCADA STREAM-FLO CROWN 11" 10000 ESPARRAGADO CON ROSCA INTERNA STUB ACME 16.250-2 STUB ACME-2G RH, 5.56" DE ESPESOR API 6A PUEE PSL-2	1

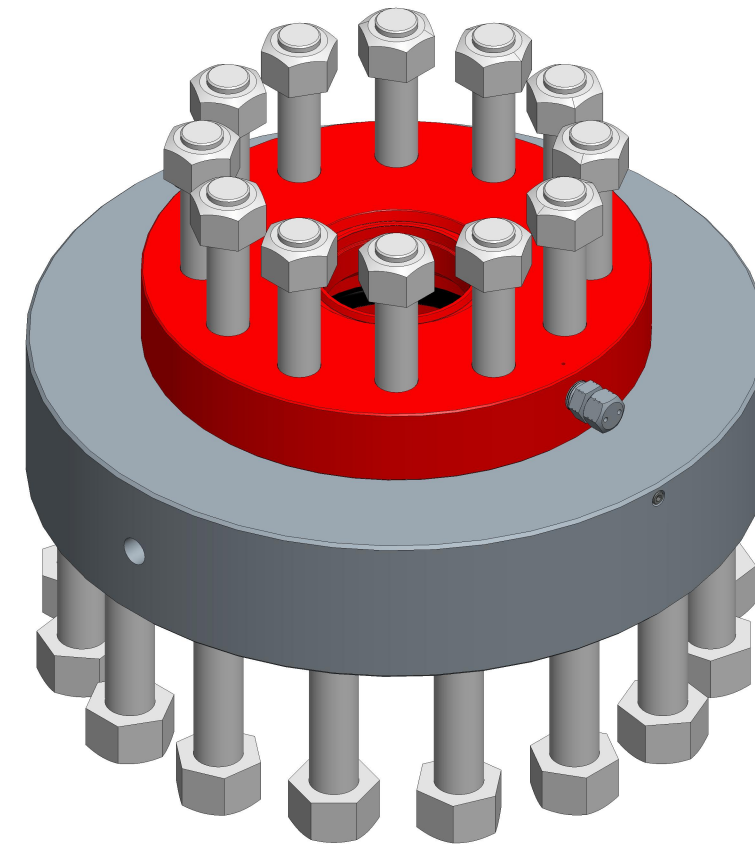
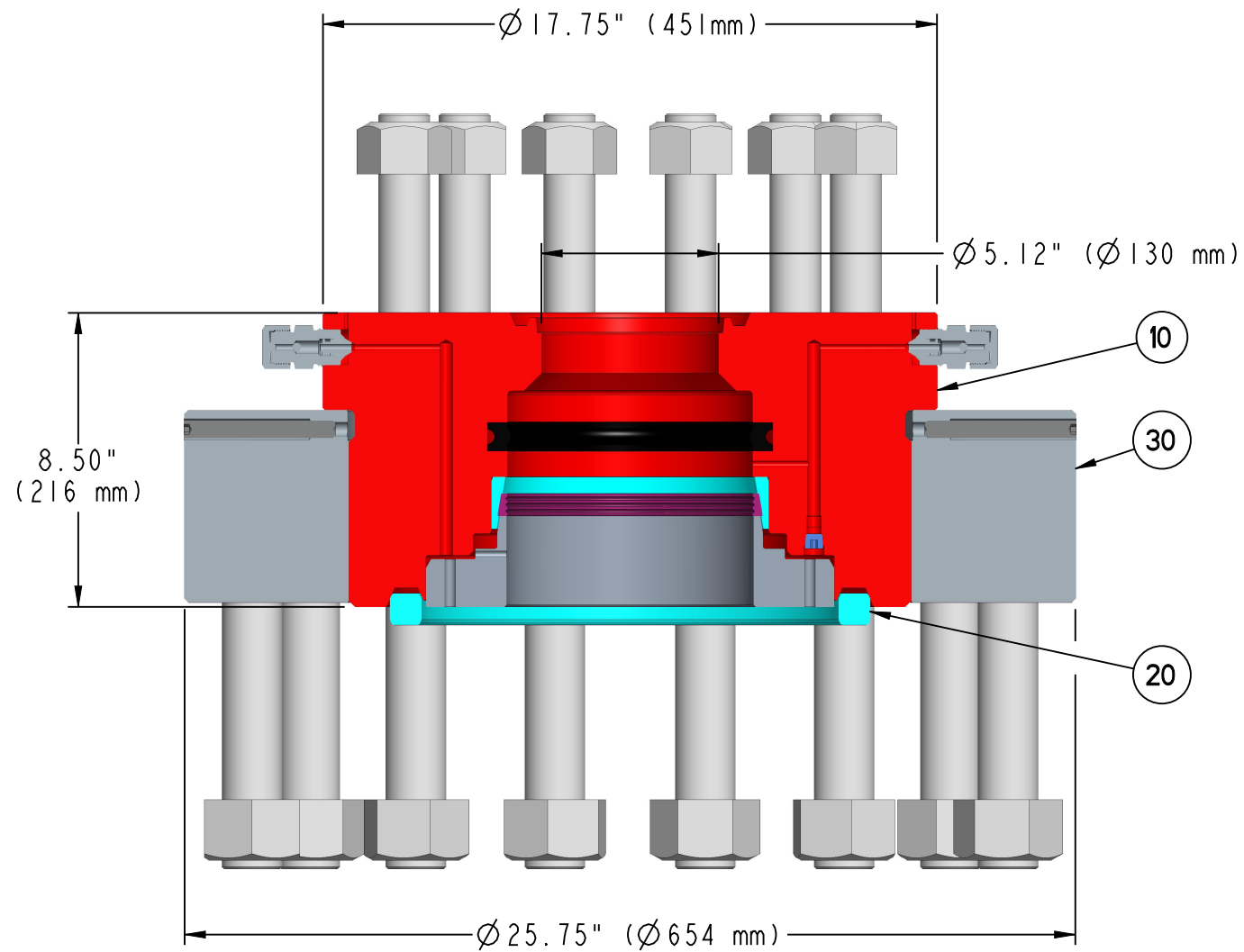

3D VIEW  
SCALE .200

REV.	EC	BY	DATE	DWN.	AT	11-25-22	ALL DIMENSIONS IN INCHES UNLESS OTHERWISE NOTED: .X +/- .1 .XX +/- .02 .XXX +/- .005 ANGLE +/- 1/2° RAD II .05 T.I.R. .010		THIS DOCUMENT IS A PROPERTY OF STREAM-FLO INDUSTRIES LTD. AND NOT TO BE USED IN ANY WAY PREJUDICIAL TO THEIR INTERESTS. ALL PROPRIETARY RIGHTS RESERVED.		4505 - 74 AVE. EDMONTON, ALTA. CANADA
				CHCK.	GAK	11-29-22					
				APPR.	JG	11-29-22					
				BY							