

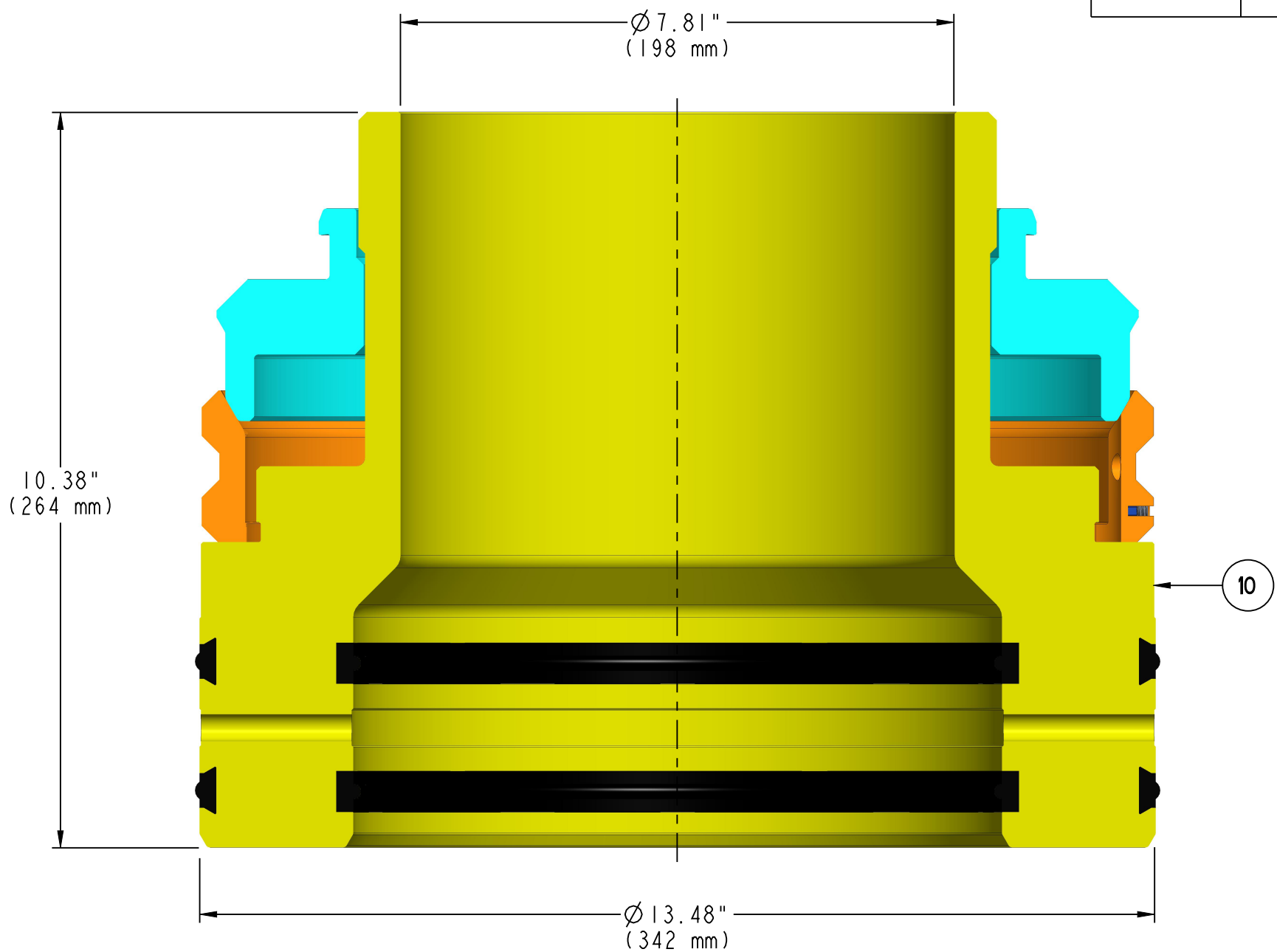

PART NUMBER 30201461 LEGACY PN: WH-23120	HEAT TREAT	MATERIAL		WEIGHT APPROX 169 lbs SCALE 0.500	YPF CATALOGUE DRAWING, PACKOFF BUSHING ASSEMBLY, DMLX 13-5/8 NOMINAL X 9.125 SEALING DIAMETER 9.000-4 STUB ACME-2G RH PIN TOP DUAL DOVETAILED S-SEALS ON OD AND DUAL S-SEALS ON ID, 7.81" BORE, 10.38" LONG, 10000 PSI	DWG. No. RB-42892
		SPEC	DWG No			REV:0 SHEET 1 OF 2

LIST OF MATERIALS			
ITEM	PART NUMBER	DESCRIPTION	QTY.
10	30201461	STREAM-FLO CROWN PACKOFF BUSHING STANDARD DMLX 13-5/8 NOMINAL X 9.125 SEALING DIAMETER 9.000-4 STUB ACME-2G RH PIN TOP DUAL DOVETAILED S-SEALS ON OD AND DUAL S-SEALS ON ID 7.81 BORE 10.38 LONG PTFE COATED 10000 psi RWP API 6A LUDD PSL-2 PR2	1



REF:	COMMONSPACE	PROJ:8082	MODEL:42892_30201461	DWN. VN 01-31-23	ALL DIMENSIONS IN INCHES	 4505 - 74 AVE. EDMONTON, ALTA. CANADA	
				CHCK. GAK 02-01-23	UNLESS OTHERWISE NOTED:		THIS DOCUMENT IS A PROPERTY OF STREAM-FLO INDUSTRIES LTD. AND NOT TO BE USED IN ANY WAY PREJUDICIAL TO THEIR INTERESTS. ALL PROPRIETARY RIGHTS RESERVED.
				APPR. RM 02-01-23	.X +/- .1	ANGLE +/- 1/2°	
REV.	EC	BY	DATE	BY	DATE	.XX +/- .02	RADII .05
						.XXX +/- .005	T.I.R. .010

PART NUMBER 30201461 LEGACY PN: WH-23120	HEAT TREAT	MATERIAL		WEIGHT APPROX 169 lbs SCALE 0.500	YPF CATALOGUE DRAWING, PACKOFF BUSHING ASSEMBLY, DMLX 13-5/8 NOMINAL X 9.125 SEALING DIAMETER 9.000-4 STUB ACME-2G RH PIN TOP DUAL DOVETAIL S-SEALS ON OD AND DUAL S-SEALS ON ID, 7.81" BORE, 10.38" LONG, 10000 PSI	DWG. No. RB-42892
		SPEC	DWG No			REV:0 SHEET 2 OF 2

LISTA DE MATERIALES			
ARTICULO	NUMERO DE PARTE	DESCRIPCION	CANT.
10	30201461	CONJUNTO PACK OFF STREAM-FLO CROWN DMLX STANDARD 13-5/8 NOMINAL Y DIAMETRO DE SELLO DE 9.125 INCLUYE ROSCA DE MANIOBRA 9.000-4 STUB ACME-2G RH PIN SUPERIOR Y DOBLE SELLO EXTERNOS E INTERNOS, 7.81 BORE, 10.38 TOTALMENTE RECUBIERTO DE PTFE 10000 psi RWP LUDD PSL-2 PR2	1

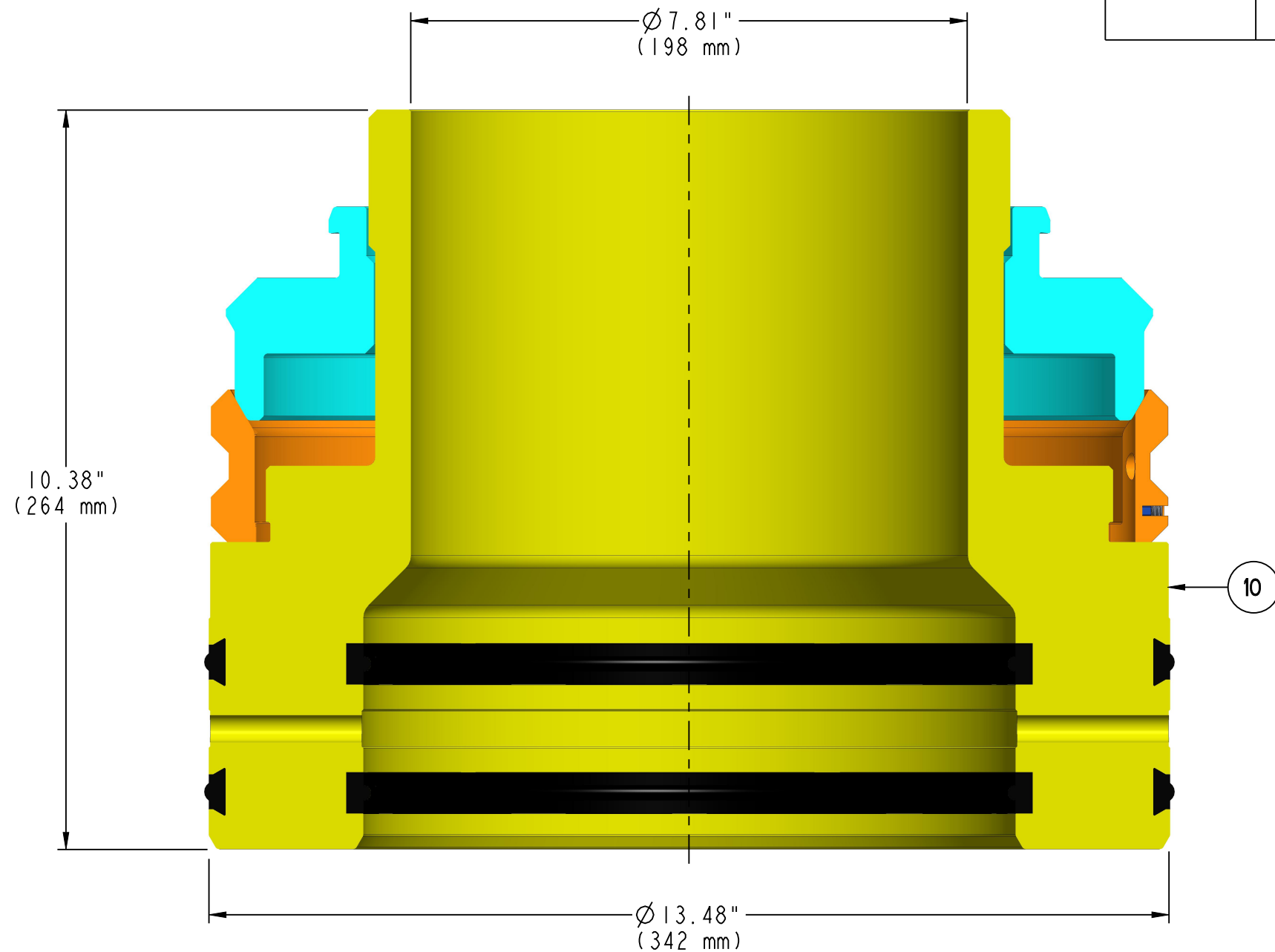

DWN.	VN	01-31-23	ALL DIMENSIONS IN INCHES UNLESS OTHERWISE NOTED: .X +/- .1 300 ANGLE +/- 1/2° .XX +/- .02 250 RADIUS .05 .XXX +/- .005 125 T.I.R. .010		
CHCK.	GAK	02-01-23			
APPR.	RM	02-01-23			
REV.	EC	BY	DATE	BY	DATE

THIS DOCUMENT IS A PROPERTY OF  
STREAM-FLO INDUSTRIES LTD. AND  
NOT TO BE USED IN ANY WAY  
PREJUDICIAL TO THEIR INTERESTS.  
ALL PROPRIETARY RIGHTS RESERVED.

