

PART NUMBER 30201352 (LEGACY PN: WH-23119)	HEAT TREAT	MATERIAL		WEIGHT APPROX	YPF ARGENTINA CATALOG DRAWING PACKOFF BUSHING ASSEMBLY, DMLX 13-5/8" NOMINAL X 10.500" SEALING DIAMETER, 10.125-4 STUB ACME-2G RH BOX TOP DUAL DOVETAIL S-SEALS ON OD AND DUAL S-SEALS ON ID, 9.97" BORE, 10000 PSI RWP	DWG. No. RB-42890
		SPEC	DWG No	153 lbs		
			SCALE 0.500		REV: 0 SHEET 1 OF 2	

LIST OF MATERIALS			
ITEM	PART NUMBER	DESCRIPTION	QTY.
10	30201352	STREAM-FLO CROWN INTERMEDIATE PACKOFF BUSHING STANDARD DMLX 13-5/8 NOMINAL X 10.500 SEALING DIAMETER 10.125-4 STUB ACME-2G RH BOX TOP DUAL DOVETAIL S-SEALS ON OD AND DUAL S-SEALS ON ID 9.97 BORE YELLOW PTFE COATED 10000 psi RWP API 6A PUDD PSL-2 PRI *RUNNING TOOL 30201456 *RETRIEVING TOOL 30201457	1

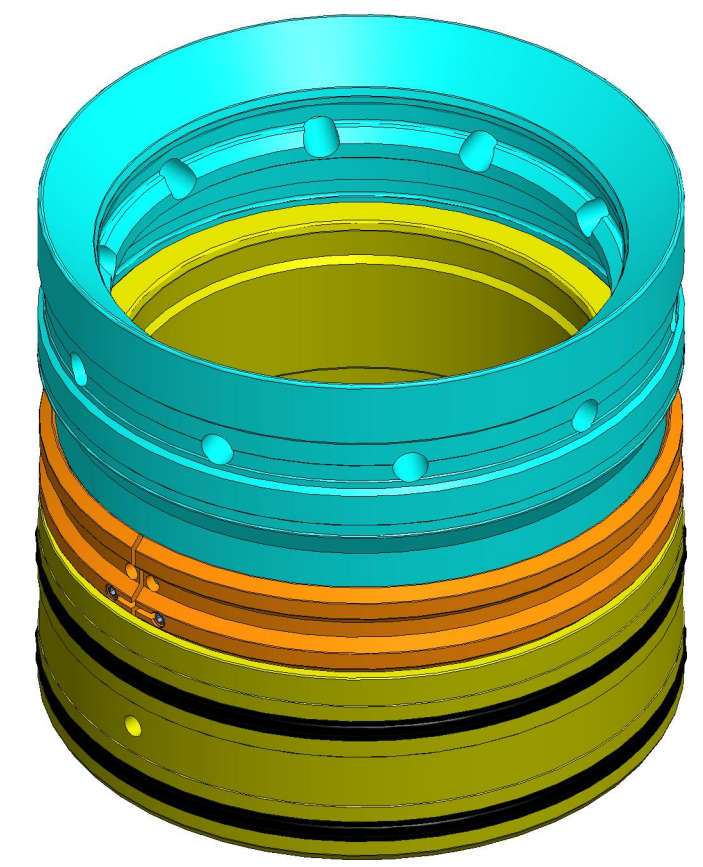
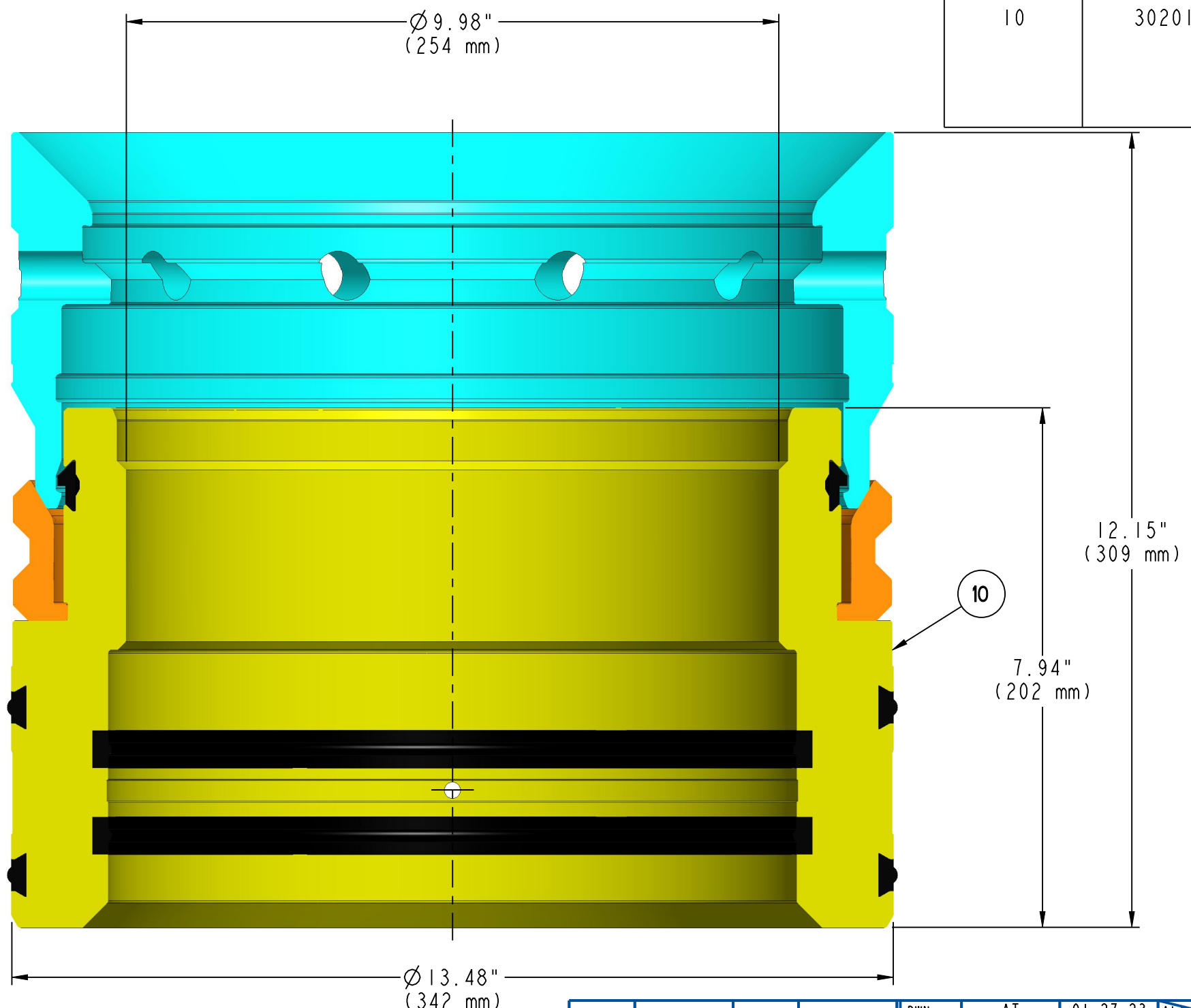

REV.	EC	BY	DATE	DWN.	AT	01-27-23	ALL DIMENSIONS IN INCHES UNLESS OTHERWISE NOTED: .X +/- .1 300 .XX +/- .02 250 .XXX +/- .005 125 ANGLE +/- 1/2° RAD II .05 T.I.R. .010		THIS DOCUMENT IS A PROPERTY OF STREAM-FLO INDUSTRIES LTD. AND NOT TO BE USED IN ANY WAY PREJUDICIAL TO THEIR INTERESTS. ALL PROPRIETARY RIGHTS RESERVED.		4505 - 74 AVE. EDMONTON, ALTA. CANADA
0				CHCK.	VN	02-01-23					
				APPR.	RM	02-01-23					
				BY							

PART NUMBER 30201352 (LEGACY PN: WH-23119)	HEAT TREAT	MATERIAL		WEIGHT APPROX	YPF ARGENTINA CATALOG DRAWING PACKOFF BUSHING ASSEMBLY, DMLX 13-5/8" NOMINAL X 10.500" SEALING DIAMETER, 10.125-4 STUB ACME-2G RH BOX TOP DUAL DOVETAIL S-SEALS ON OD AND DUAL S-SEALS ON ID, 9.97" BORE, 10000 PSI RWP	DWG. No. RB-42890
		SPEC	DWG No	153 lbs		
			SCALE 0.500		REV: 0 SHEET 2 OF 2	

LISTA DE MATERIALES			
ARTICULO	NUMERO DE PARTE	DESCRIPCIO	CANT.
10	30201352	CONJUNTO PACK OFF STREAM-FLO CROWN DMLX STANDARD 13-5/8" NOMINAL Y DIAMETRO DE SELLO DE 10,5 INCLUYE ROSCA DE MANIOBRA 10.125-4 STUB ACME-2G RH BOX SUPERIOR Y DOBLE SELLO EXTERNOS E INTERNOS. 9,97 BORE; 7,94 LARGO CON RECUBRIMIENTO DE PTFE 10000 psi. API 6A PU/DD/PSL-2/PR-1	1

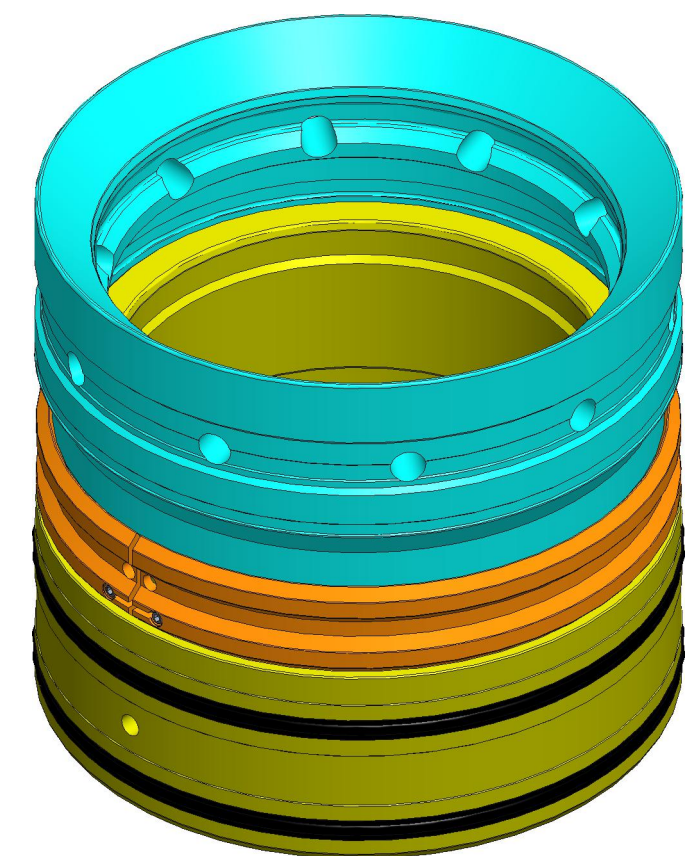
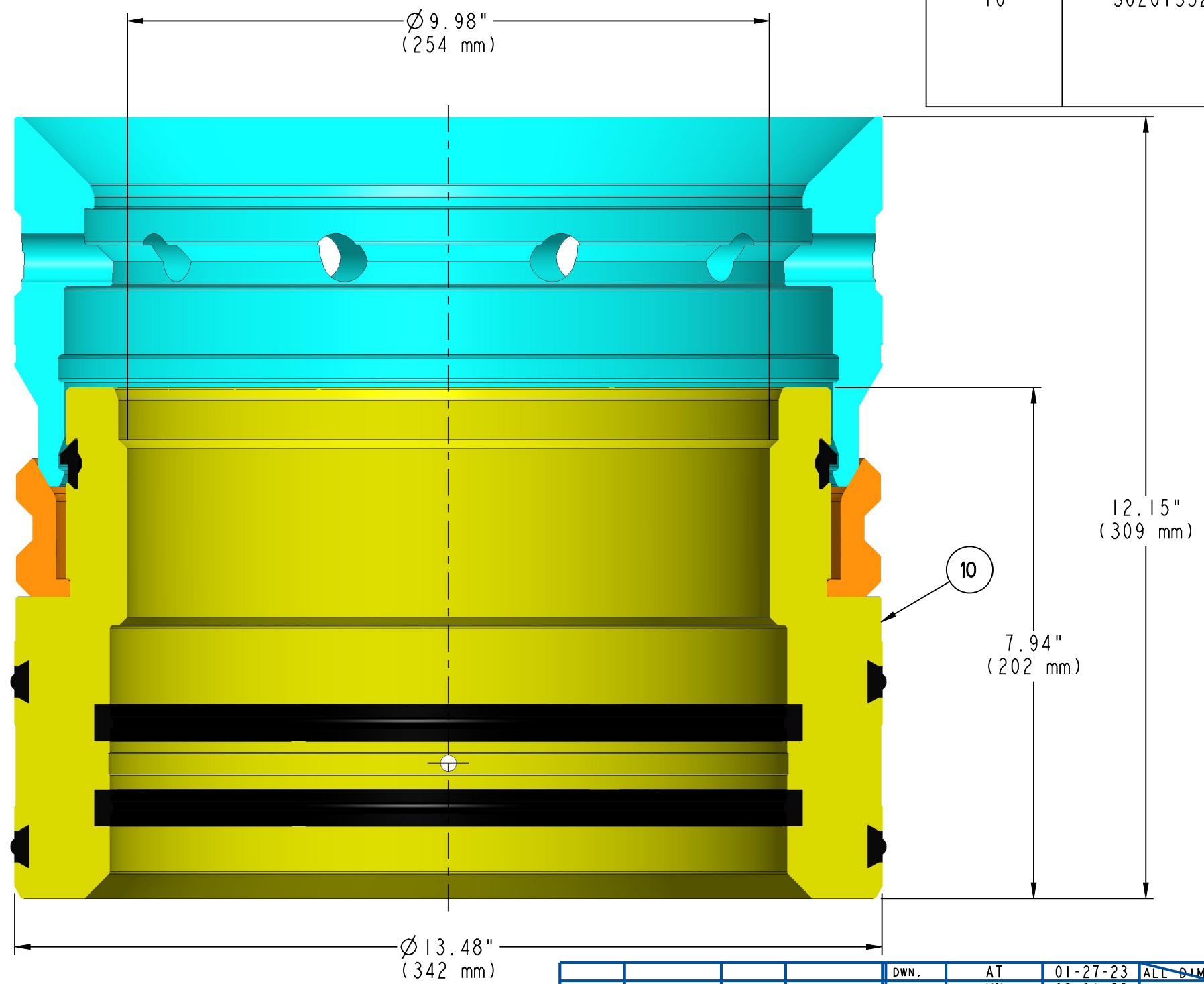

3D VIEW
SCALE 0.250

REV.	EC	BY	DATE	DWN.	AT	01-27-23	ALL DIMENSIONS IN INCHES UNLESS OTHERWISE NOTED: .X +/- .1 .XX +/- .02 .XXX +/- .005 ANGLE +/- 1/2° RADII .05 T.I.R. .010
0				CHCK.	VN	02-01-23	
				APPR.	RM	02-01-23	

THIS DOCUMENT IS A PROPERTY OF
STREAM-FLO INDUSTRIES LTD. AND
NOT TO BE USED IN ANY WAY
PREJUDICIAL TO THEIR INTERESTS.
ALL PROPRIETARY RIGHTS RESERVED.



4505 - 74 AVE.
EDMONTON, ALTA.
CANADA